

FEKAFOS 280 DOUBLE

AUTOMATIC PUMPING STATION FOR 2 PUMPS



TECHNICAL DATA

Operating range:

from 1 to 32 m³/h with a head of up to 23 mt.

Pumped liquid: ground water, rain water, clear waste water, black waste water and water from rivers and lakes.

Maximum liquid temperature range: 45°C

Installation: Inside or outside the building. Laid on the floor, under the ground or housed.

Not suitable for vehicles but walkable up to 100 Kg.

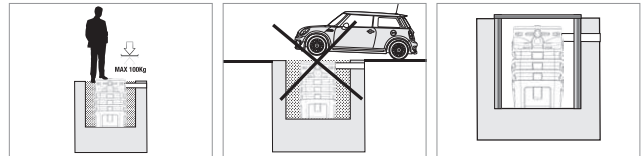

APPLICATIONS

Pump station useful for the collection and transport in sewer of domestic waste water (sewage, rainwater and gray water), from basements or garages of one or more housing units, when the drainage system can not be achieved by gravity.

CONSTRUCTIVE CHARACTERISTICS

CAPACITY: 280 lt

MATERIAL: LLDPE

REGULATIONS: 12050-1

CONNECTIONS:

- Input DN 50/110
- Ventilation DN 50
- Output G2"

COMPONENTS INCLUDED:

- 2 lifting devices DSD2" and anti-rotation bracket for FEKA VS e VX
- 6 Cables gland for single pump and floats
- 2 Floatings cables clamp kit FEKA VS e VX
- 3 Floats and floatin alarm support

COMPONENTS EXCLUDED:

- Pump: to be selected according to the configuration possibilities
- Control panel: to be selected according to the configuration possibilities
- Max switching float alarm

PUMP INSTALLATION

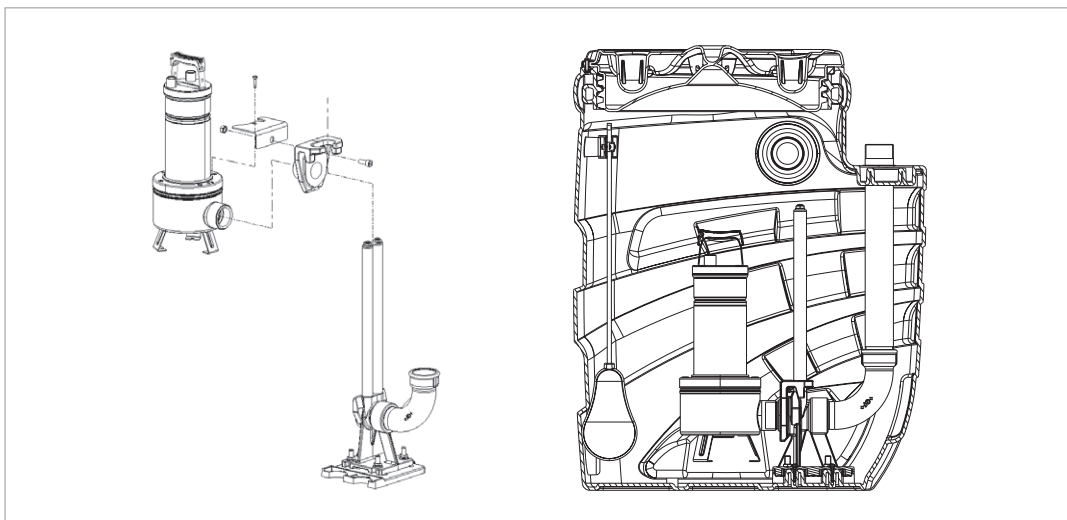

FEKAFOS 280 DOUBLE - WASTE WATER COLLECTION AND LIFTING

Maximum liquid temperature range: 45°C

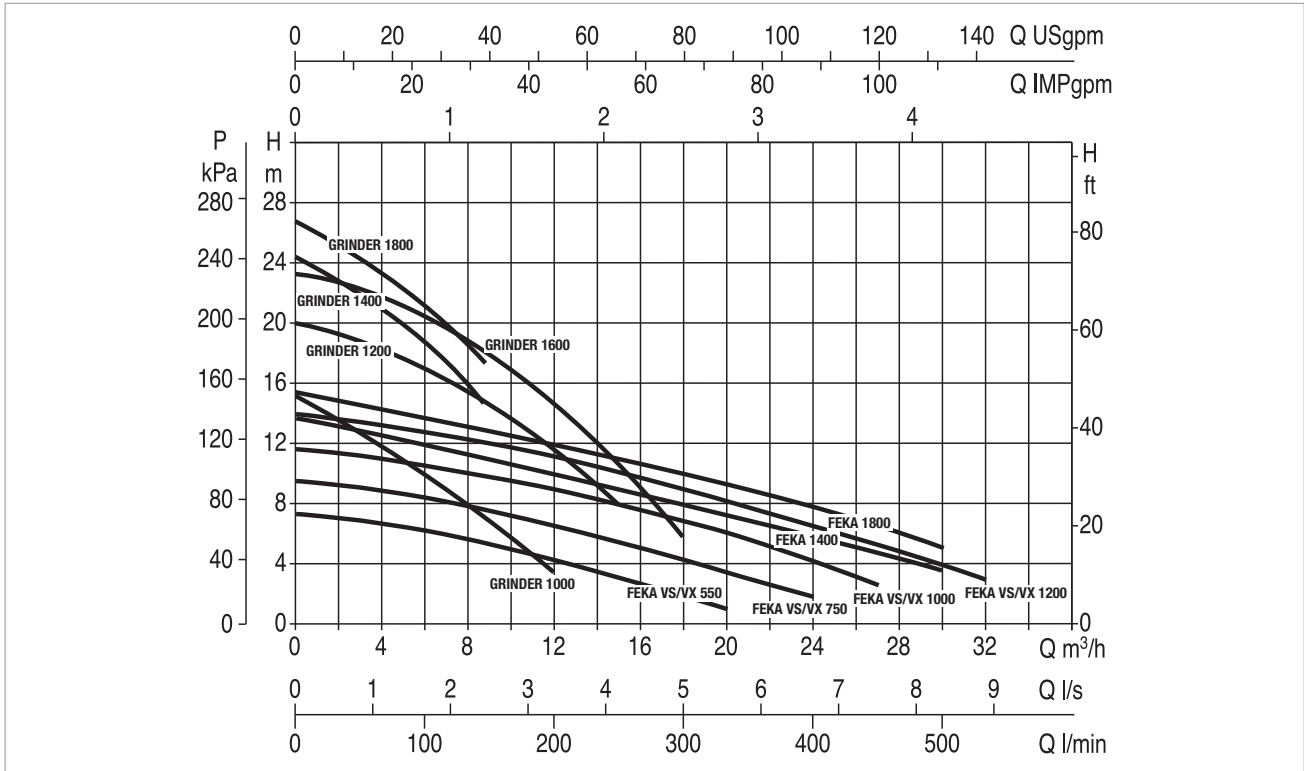

Performance curves are based on kinematic viscosity values = 1 mm²/s and density of 1000 Kg/m³. Curve tolerance in accordance with ISO 9906.

CONFIGURATION

PUMP MODEL	ELECTRICAL DATA				CONTROL PANEL MATCHING	
	VOLTAGE 50 HZ	P1 MAX kW	P2 NOMINAL			In A
			kW	HP		
FEKA VS/VX 550 M-NA	1X220 - 240 V~	0,9	0,55	0,75	4,2	E2D 2 M / E-BOX 2D M/T
FEKA VS/VX 550 T-NA	3X400 V~	0,9	0,55	0,75	1,64	E2D 2 T / E-BOX 2D M/T
FEKA VS/VX 750 M-NA	1X220 - 240 V~	1,1	0,75	1	5,13	E2D 2 M / E-BOX 2D M/T
FEKA VS/VX 750 T-NA	3X400 V~	1,1	0,75	1	1,94	E2D 2 T / E-BOX 2D M/T
FEKA VS/VX 1000 M-NA	1X220 - 240 V~	1,4	1	1,36	6,63	E2D 3 M / E-BOX 2D M/T
FEKA VS/VX 1000 T-NA	3X400 V~	1,4	1	1,36	2,51	E2D 3 T / E-BOX 2D M/T
FEKA VS/VX 1200 M-NA	1X220 - 240 V~	1,9	1,2	1,6	8,63	E2D 3 M / E-BOX 2D M/T
FEKA VS/VX 1200 T-NA	3X400 V~	1,9	1,2	1,6	3,44	E2D 3 T / E-BOX 2D M/T
FEKA 1400 M	1X220 - 240 V~	1,8	1,1	1,5	8,5	E2D 6 M 40 µF / E-BOX 2D 40 µF
FEKA 1800 T	3X400 V~	1,9	1,5	2,0	3,7	E2D 3 T / E-BOX 2D M/T
GRINDER 1400 M	1X220 - 240 V~	1,9	1,1	1,5	8,7	E2D 6 M HS
GRINDER 1800 T	3X400 V~	2	1,5	2,0	3,8	E2D 3 T / E-BOX 2D M/T
GRINDER 1000 M-NA	1X220 - 240 V~	1,5	1	1,3	8	E2D 3 M / E-BOX 2D M/T
GRINDER 1000 T	3X400 V~	1,6	1	1,3	2,8	E2D 3 T / E-BOX 2D M/T
GRINDER 1200 M-NA	1X220 - 240 V~	2,8	1,5	2	12,7	E2D 4 M / E-BOX 2D M/T
GRINDER 1200 T	3X400 V~	2,7	1,5	2	4,7	E2D 5 T / E-BOX 2D M/T
GRINDER 1600 M-NA	1X220 - 240 V~	3,8	1,8	2,4	16,8	E2D 4,8 M / E-BOX 2D M/T
GRINDER 1600 T	3X400 V~	3,3	1,8	2,4	5,8	E2D 5 T / E-BOX 2D M/T

FEKAFOS 280 DOUBLE - WASTE WATER COLLECTION AND LIFTING



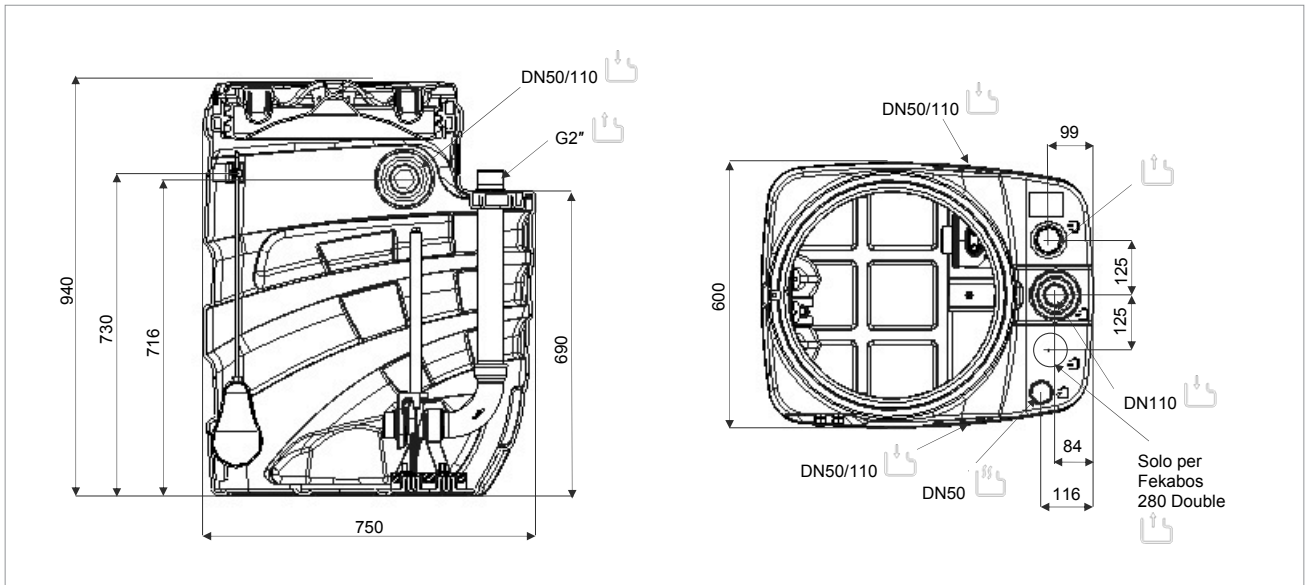

Maximum liquid temperature range: 45°C



DIMENSIONS AND WEIGHTS

PACKAGING DIMENSIONS			WEIGHT Kg
L/A	L/B	H	
750	600	940	53,7

LEGEND:

-  → Connection of delivery pipe or emergency outlet
-  → Collection pipe inlet
-  → Outlet of power cables and float cables
-  → Connection of ventilation pipe
-  → Recyclable material